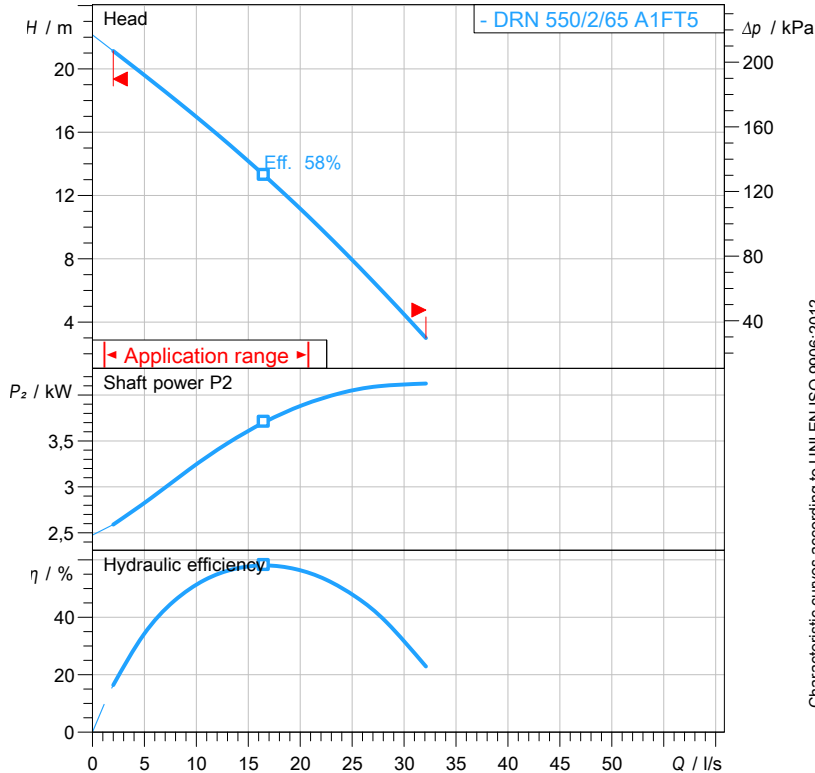
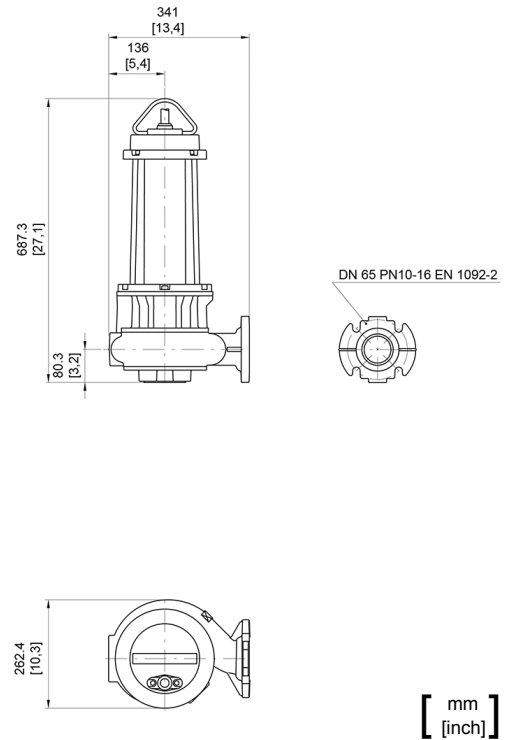

Technical specification
3~ 50 Hz

 Characteristic curves according to UNI EN ISO 9906:2012
 P2 < 10kW: paragraph 4.4.2
 10kW < P2 < 100kW: Grade 3B
 P2 > 100kW: Grade 2B

Pump

Series	N series
Pump name	DRN 550/2/65 A1FT5
Configuration	NGTAB51040S00EX
Standard	ATEX 2014/34/EU
ATEX mark	II 2GD Ex db k IIB T5 Ex tb IIIC T100°C IP68

Operating limits (standard pumps)

Max. ambient temperature	40 °C
Max. density treated liquid	1100 kg/m ³
pH treated liquid	6 ÷ 14
Max. start per hour (equally distributed)	30
Wet/dry use	WET
Max. acoustic pressure level	70 dB
Operating mode	S1 - Continuous use

Motor data

Rated voltage	400 V
Frequency	50 Hz
Motor phases	3~
Number of poles	2
Rated power P2	4,10 kW
Incoming power P1	5,00 kW
Rated current	8,7 A
rpm	2880 1/min
cos φ	0,83
Rated torque	13,6 Nm
Start	Direct starting
Degree of protection	IP 68
Insulation class	H

Construction materials

Case	Cast iron EN-GJL 250
Shaft	Stainless steel - AISI 431
Hydraulic	Cast iron - EN-GJL 250
Impeller	Cast iron - EN-GJL 250
Painting/Coating	Bi-epoxy 200 μm
Screws	Stainless steel - Class A2-70
Gaskets	VITON
Cooling jacket (if present)	Carbon steel

Construction features

Cooling system	No cooling jacket
Main cable	4G2.5+3x1
Control cable	-
Cable length	10 mt
Mechanical seals	2 in silicon carbide (2SiC)
Additional drilling	-
Weight*	77 kg
Electrical variant	Thermal protection

* cable's weight not included

Hydraulic

Type	DR (Multi-channel open)
Free passage	50 mm
Impeller type	Open channel impeller
Max. hydraulic efficiency	58,0 %
Suction	DN 65 EN 1092-2
Discharge	DN 65 EN 1092-2
Curve tolerance	UNI EN ISO 9906:2012



water solutions

Data sheet DRN 550/2/65 A1FT5



N series

Pump performance curves

3~ 50 Hz

Hydraulic type DR (Multi-channel open)		Impeller type Open channel impeller		Free passage 50 mm	Discharge DN 65	Suction DN 65
DUTY POINT						
Flow	Head	Shaft power P2	Hydraulic efficiency	Density 998,3 kg/m ³	Viscosity 1,005 mm ² /s	

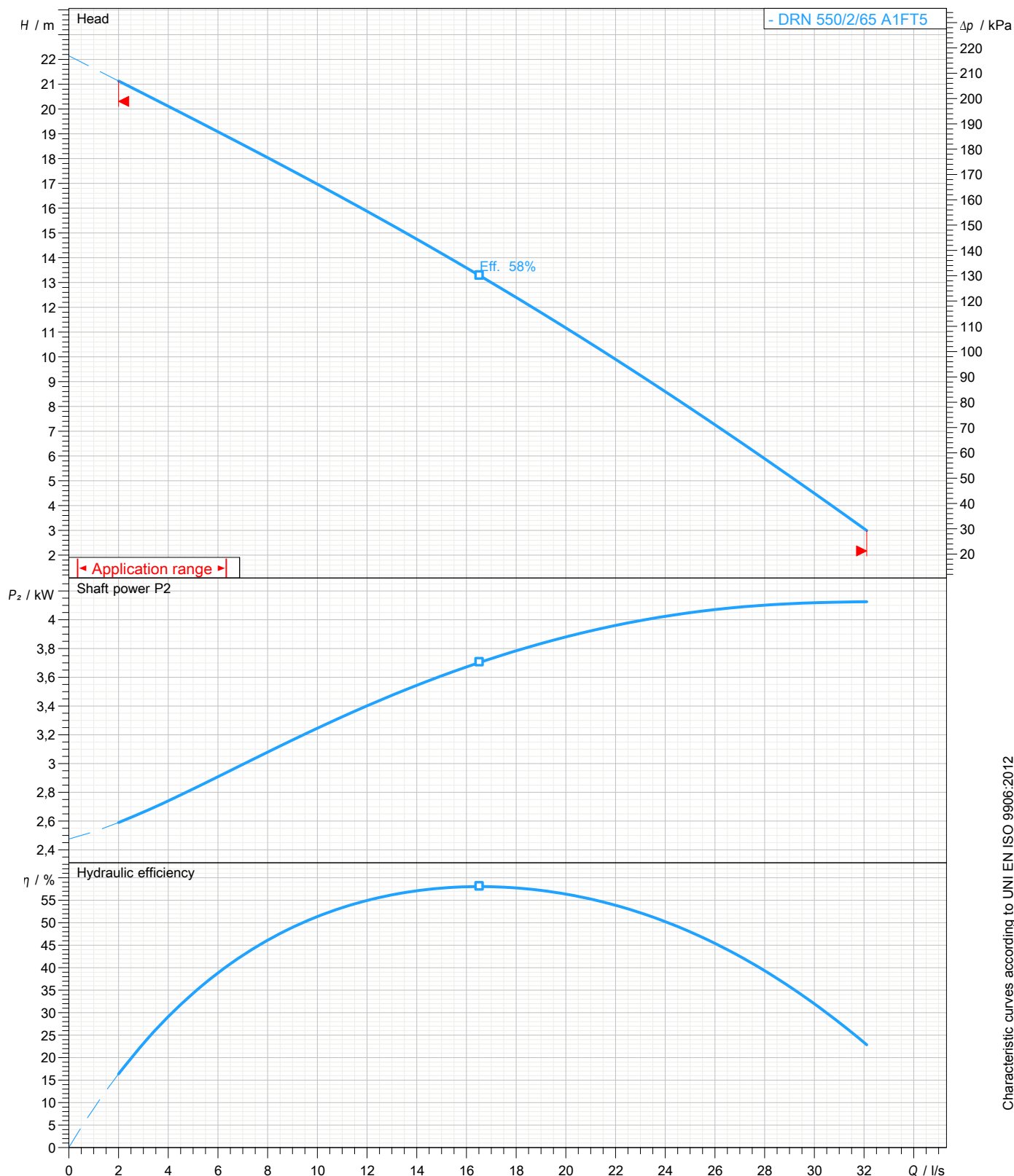

Characteristic curves according to UNI EN ISO 9906:2012
 P2<10kW: paragraph 4.4.2
 10kW<P2<100kW: Grade 3B
 P2>100kW: Grade 2B



water solutions

Data sheet DRN 550/2/65 A1FT5



N

series

Dimensional drawing

3~ 50 Hz

Installation type Installation with bottom coupling device - Vertical outlet

WET/DRY use: WET

Discharge: DN 65 EN 1092-2

Suction: DN 65 EN 1092-2

Pressure rating (suction/discharge): PN 6/PN 10

Accessory * : DAC 65/65V+KAF 116-2" EN (P)

Accessory code * : 9001.031

* Accessory must be ordered separately

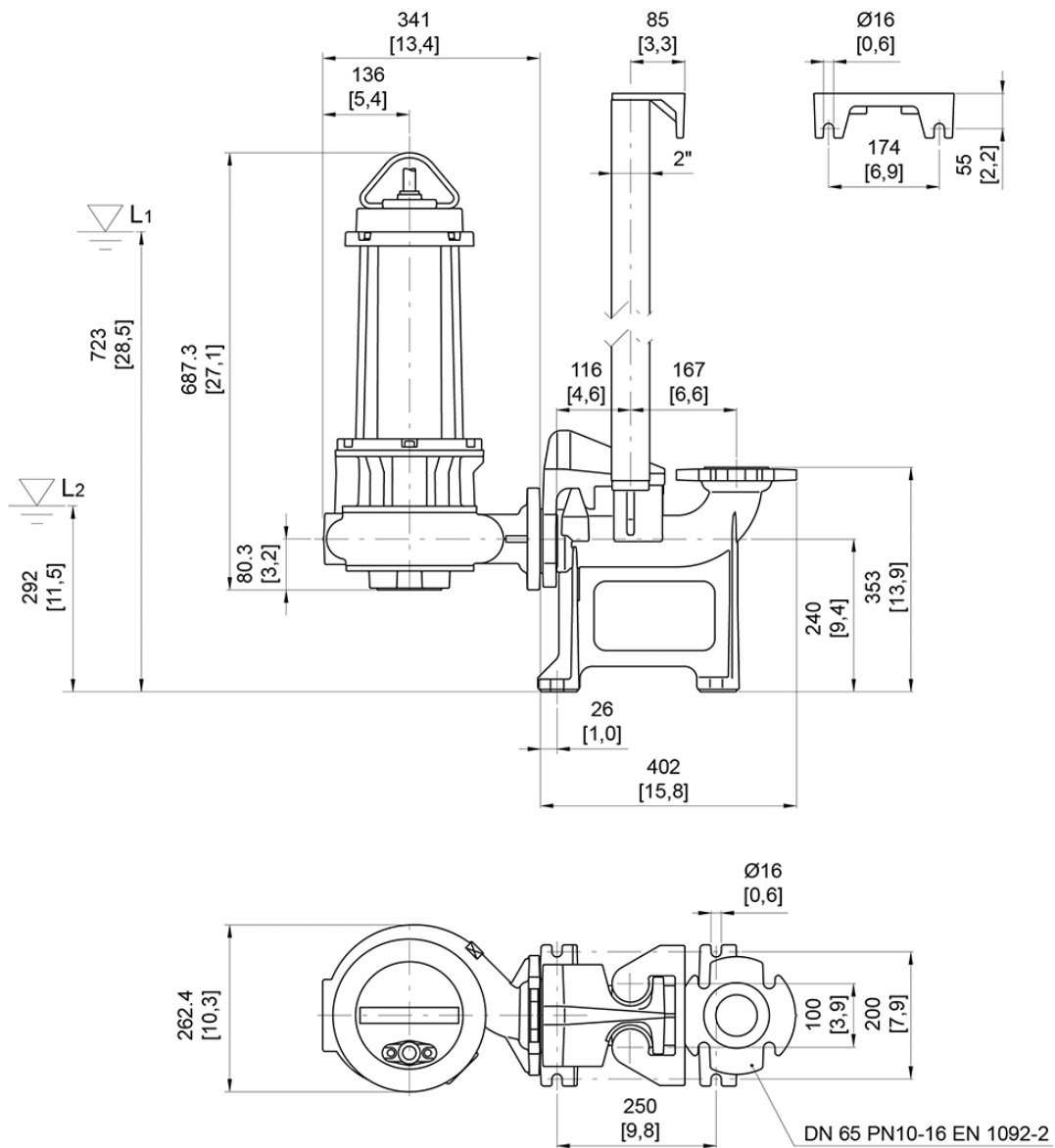

L1: Minimum operating level for continuous use

L2: Minimum operating level for discontinuous use (only "WET" version)

[mm]
[inch]